

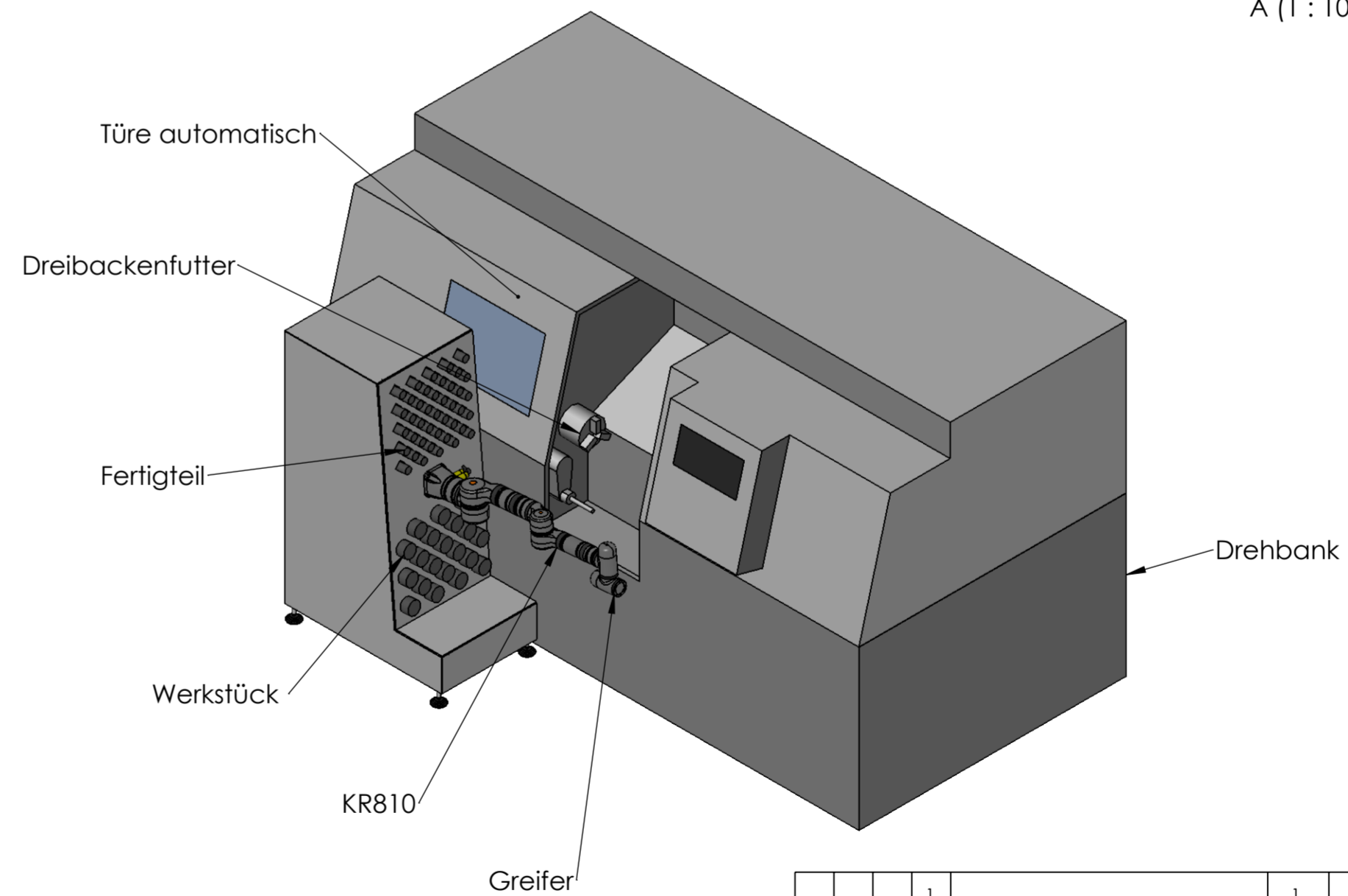

A (1 : 10)

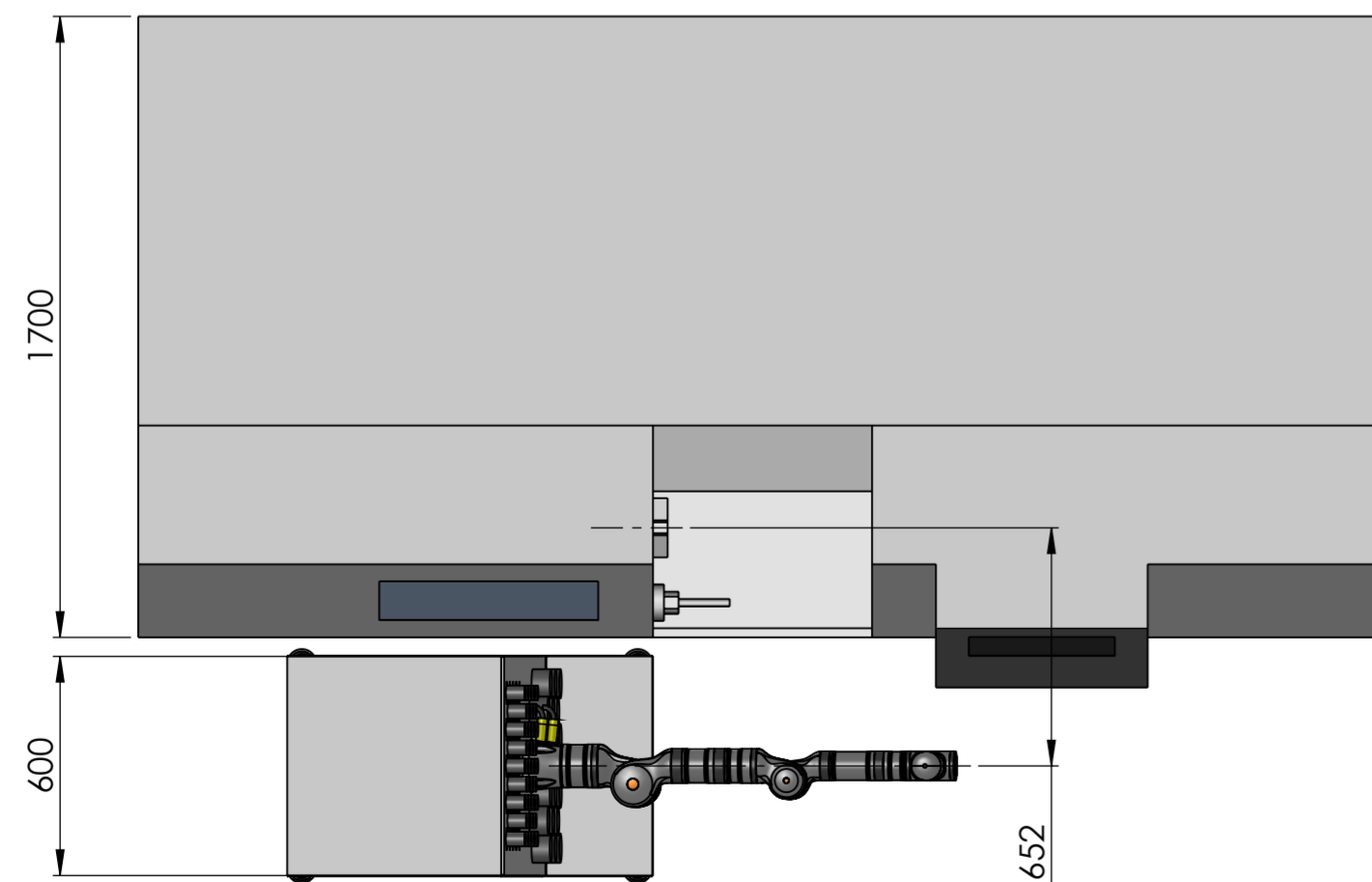

1	1	73448105.69			
Stueckzahl	Gegenstand und Dimension	Pos.	Werkstoff	Gew.p.St.	Zusammenst.-Nr.
IV	III	II	I	Alle Masse und Toleranzen gelten für <b>fertiges Bauteil</b> (nach Wärme-, Oberflächen- und Farbbehandlungen)	
KR810 CNC System				Massstab 1:20	Gezeichnet 23.12.22 Geprüft Gesehen
HEFTEC GmbH Automation & Engineering				 <b>SCO.000.1398</b>	