

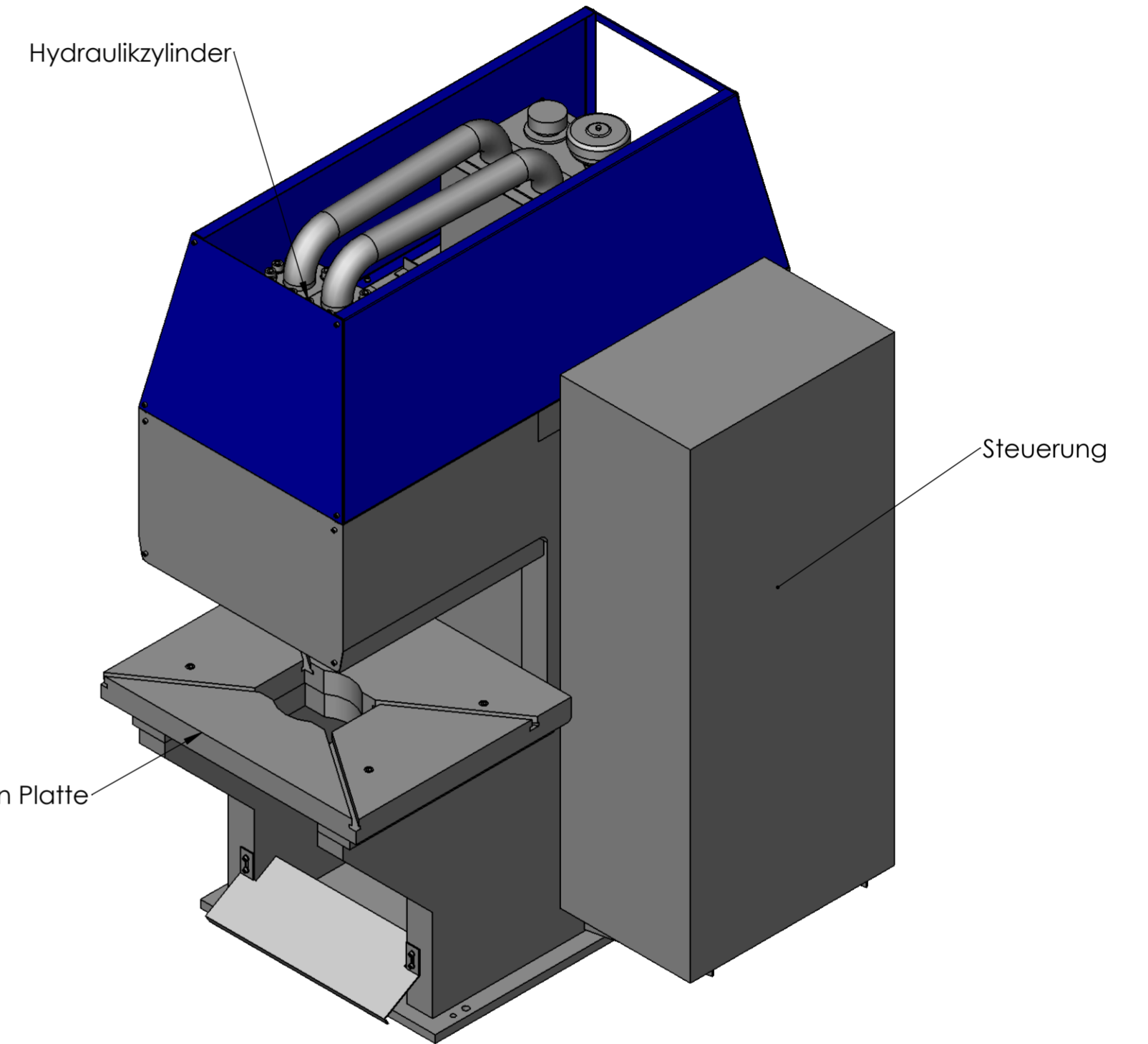

A-A

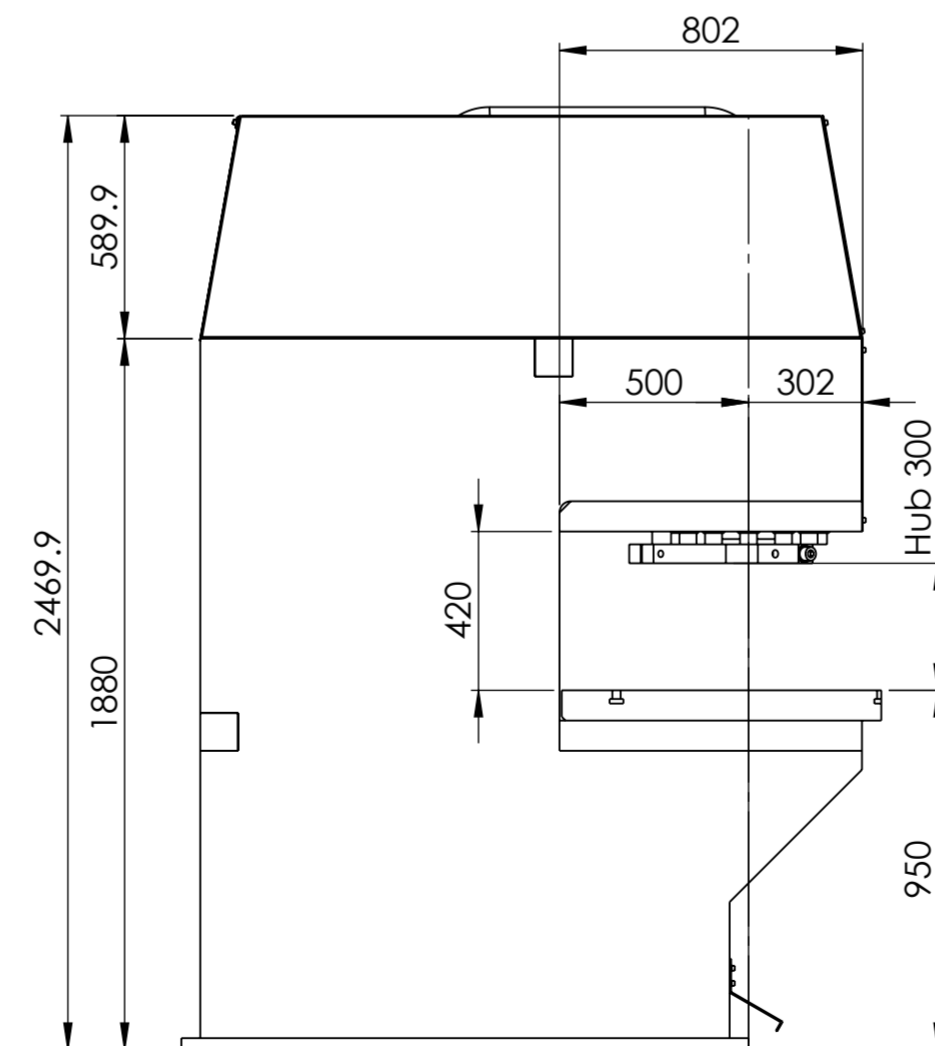

T-Nuten Platte

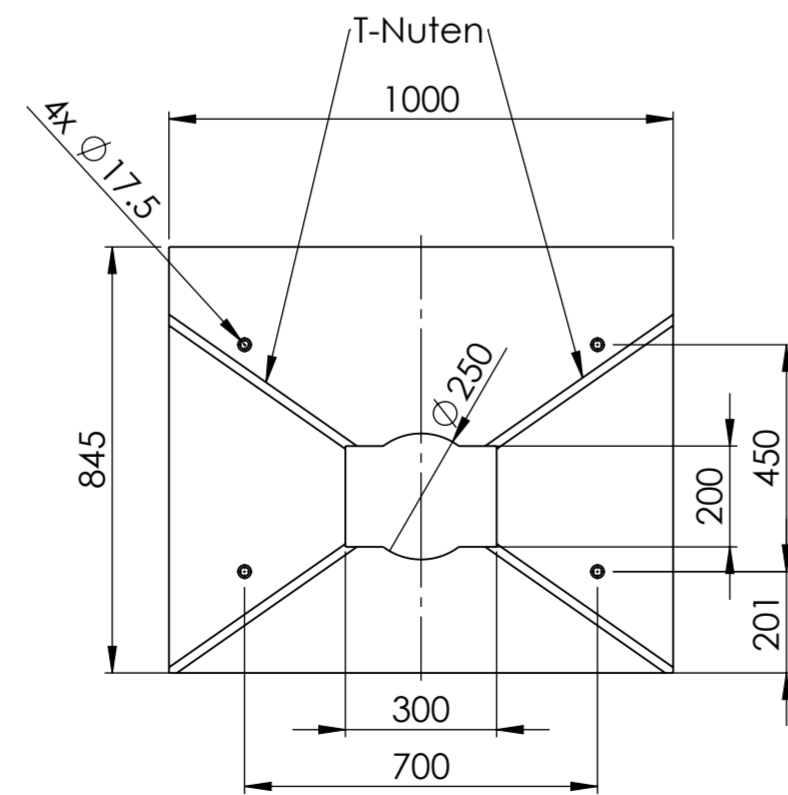
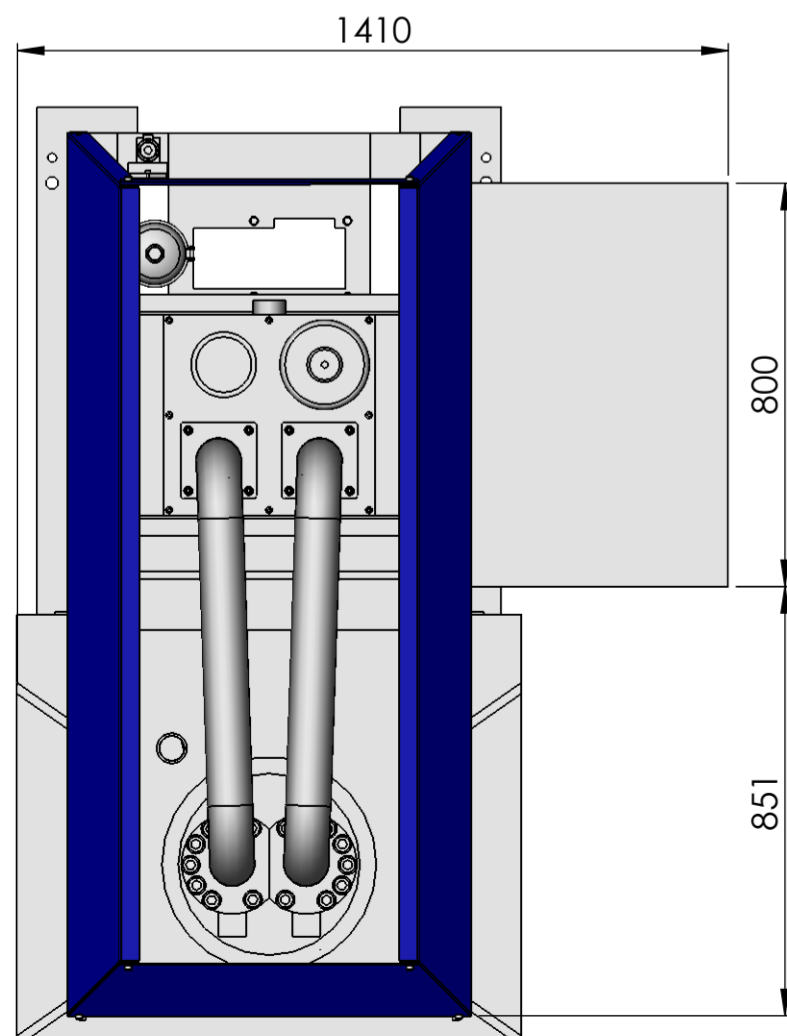

Stempelgeschwindigkeit auf	370 mm/s	Dimension	1400x1851x2490
Stempelgeschwindigkeit ab	36 mm/s	Gewicht	7000 kg
Stueckzahl	1	Pos.	1
Gegenstand und Dimension		Werkstoff	7041255.17
		Gew.p.St.	Zchng.-Nr. / Norm-Nr. / Artikel-Nr. / Bemerkungen
IV	III	II	I
			Zusammenst.-Nr.
HP1000C Hydraulikpresse 1000 kN HEFTEC GmbH Automation & Engineering			Massstab 1:15 Gezeichnet 22.02.22 fl Geprueft Gesehen
			 PRE.000.1203