

BPM3000S - UNIVERSAL CARTON FILLING MACHINE

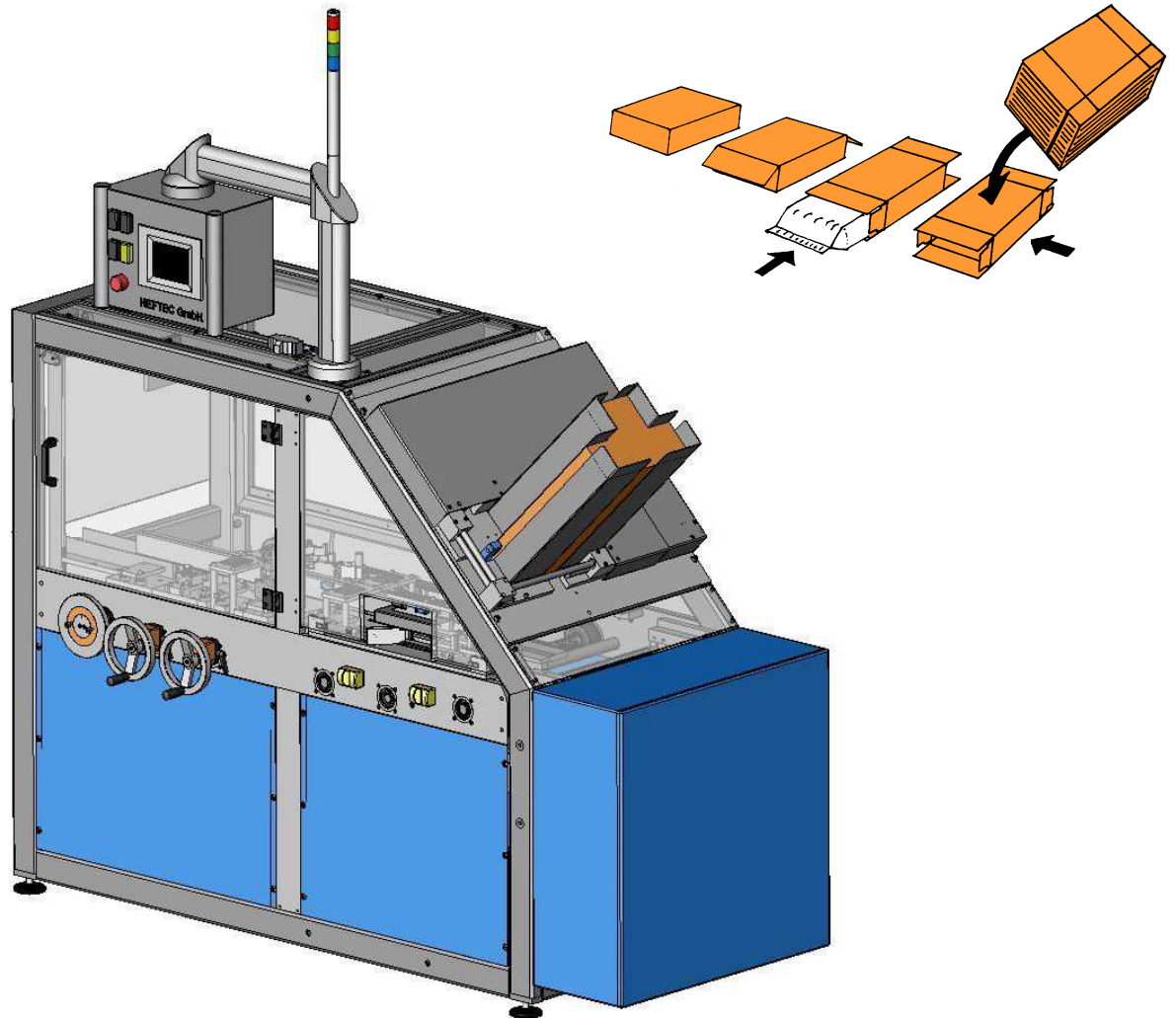

- **Universal horizontal cartoning machine, with adhesive or push-in flap** (The machine can be very simply re-adjusted to accept various packaging requirements)
- **Product output: up to 3000 cartons per hour** (Depending on the carton size and shape)
- **With manual or automatic filling station**
- **Control system with touch-screen HMI and PLC controller**
- **Option: Available in stainless steel execution**
- **Option: With fully automated in-feed system**
- **Option: Available in mirror image execution**

BPM3000S - UNIVERSAL CARTON FILLING MACHINE

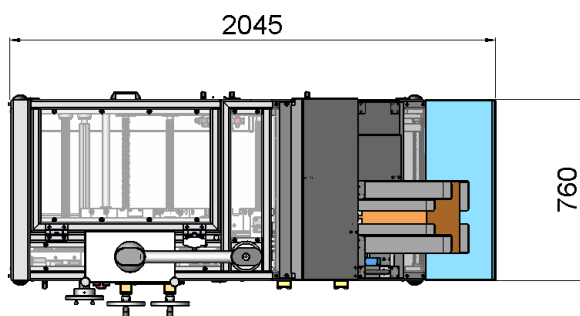
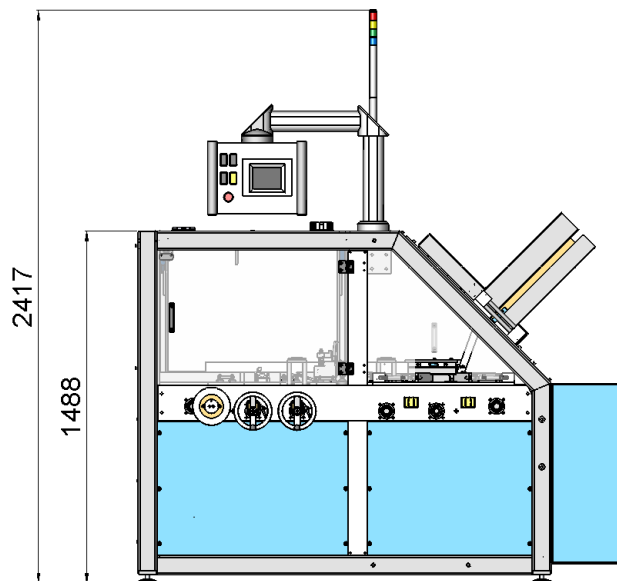
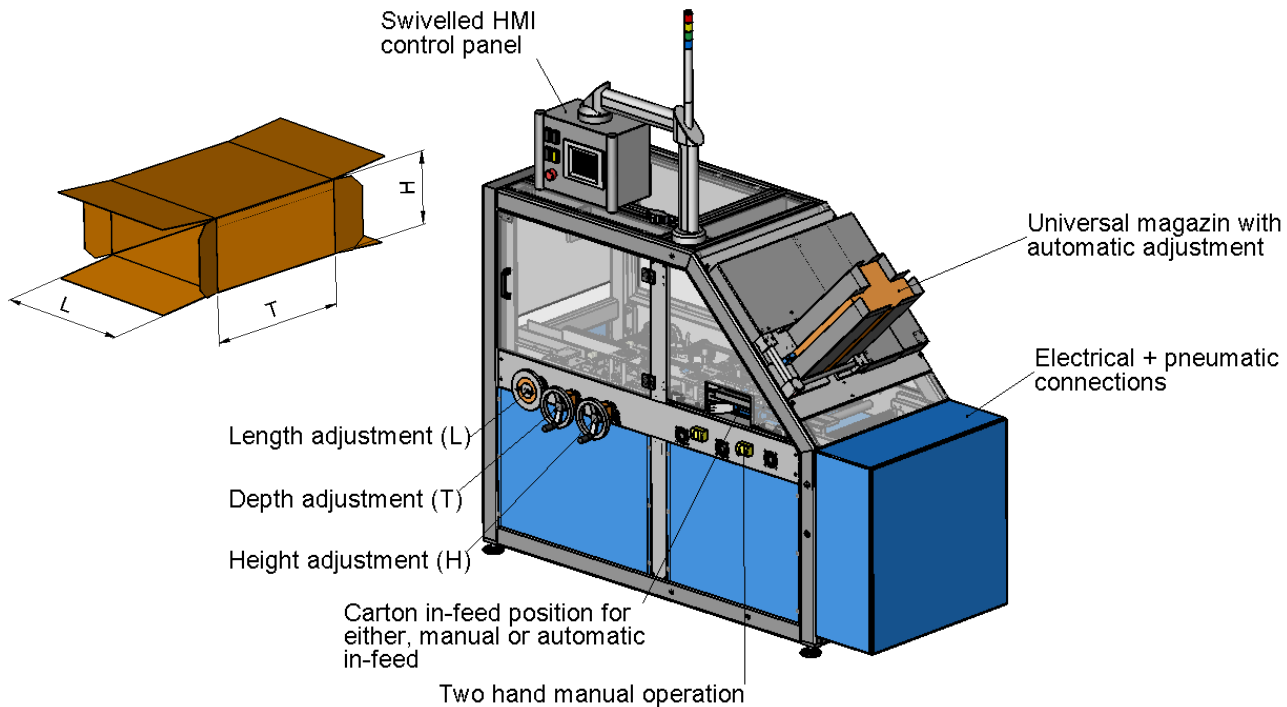

BPM3000S Technical Data

Dimensions	Carton sizes for:-
	9 Stations: 7 Stations:
Depth:	74-500 mm 74-500 mm
Length:	20-140 mm 20-190 mm
Height:	20-140 mm 20-140 mm
Output rate:	Up to 3000 cartons per hour. (Depending on the product dimensions and shape.)
Electrical mains supply:	3 x 400V, 50/60Hz
Controls:	PLC type Siemens S7-300
Compressed air:	6 bar / 90psi at approx. 40 Liter / Minute
Weight:	750 kg
Options:	Adhesive sealing Plush in flap closure Automatic in-feed system Add instruction sheet Printing Pharma- und Food industry conformity